

NB7VPQ701M

1.8 V USB 3.1 Single Channel Re-driver

Description

The NB7VPQ701M is a 1.8 V single channel re-driver for USB 3.1 Gen 1 and USB 3.1 Gen 2 applications that supports both 5 Gbps and 10 Gbps data rates. Signal integrity degrades from PCB traces, transmission cables, and inter-symbol interference (ISI). The NB7VPQ701M compensates for these losses by engaging varying levels of equalization at the input receiver and de-emphasis on output driver. The output transmitter circuitry provides user selectable de-emphasis and output amplitude settings to create the best eye openings for the outgoing data signals.

The NB7VPQ701M features an intelligent LFPS circuit. This circuit senses the low frequency signals and automatically disables driver de-emphasis for full USB 3.1 Gen 1 and USB 3.1 Gen 2 compliances.

After power up, the NB7VPQ701M periodically checks both of the TX output pairs for a receiver connection. When the receiver is detected the RX termination becomes enabled and the NB7VPQ701M is set to perform the re-driver function.

The NB7VPQ701M comes in a small, ultra-thin 1.6 x 1.6 mm UQFN12 package and is specified to operate across the entire industrial temperature range, -40°C to 85°C.

Features

- 1.8 V \pm 5% Power Supply
- Device Supports USB 3.1 Gen 1 and USB 3.1 Gen 2 Data Rates
- Automatic LFPS De-Emphasis Control
- Automatic Receiver Termination Detection
- Integrated Input and Output Termination
- Selectable Equalization, De-Emphasis, and Output Swing
- Chip Enable Pin for Deep Power-Saving Mode
- Hot-Plug Capable
- ESD Protection \pm 4 kV HBM
- Operating Temperature Range: -40°C to 85°C
- Small 1.6 x 1.6 x 0.5 mm UQFN12 Package
- This is a Pb-Free Device

Typical Applications

- Mobile Phone and Tablet
- Computer and Laptop
- Docking Station and Dongle
- Active Cable, Back Planes
- Gaming Console, Smart T.V.



ON Semiconductor®

www.onsemi.com



UQFN12
CASE 523AV

MARKING DIAGRAM

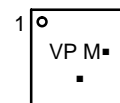

VP = Specific Device Code
M = Date Code
▪ = Pb-Free Package

(Note: Microdot may be in either location)

ORDERING INFORMATION

Device	Package	Shipping†
NB7VPQ701MMUTBG	UQFN12 (Pb-Free)	3000 / Tape & Reel

†For information on tape and reel specifications, including part orientation and tape sizes, please refer to our Tape and Reel Packaging Specifications Brochure, BRD8011/D.

NB7VPQ701M

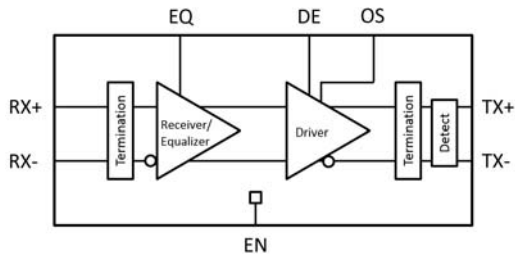

Figure 1. Logic Diagram of NB7VPQ701M

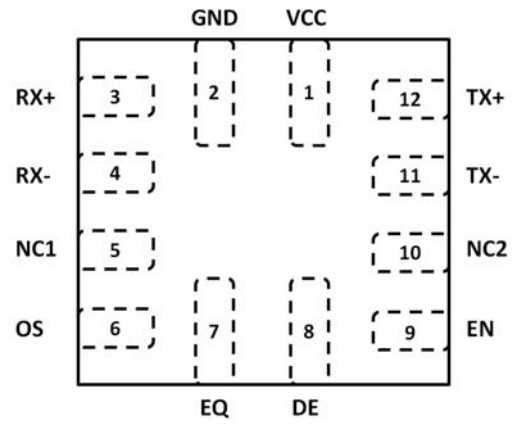

Figure 2. UQFN12 Package Pinout (Top View)

Table 1. PIN DESCRIPTION

Pin Number	Pin Name	Type	Description
1	VCC	Power	1.8 V power supply
2	GND	Power	Reference Ground
3	RX+	Differential Input Pair	Differential input pair for 5 / 10 Gbps USB signals. Must be externally AC-coupled.
4	RX-		
5	NC1	N/A	No connect – float pin
6	OS	CMOS Input	Sets output amplitude on the TX. 3-state input with integrated 250 k Ω pull-up and pull-down resistors
7	EQ	CMOS Input	Sets equalizer gain on the RX. 3-state input with integrated 250 k Ω pull-up and pull-down resistors.
8	DE	CMOS Input	Sets the output de-emphasis. 3-state input with integrated 250 k Ω pull-up and pull-down resistors.
9	EN	CMOS Input	Chip enable input (active high), internal 550 k Ω pull-up resistor. Low to power down.
10	NC2	N/A	No connect – float pin
11	TX-	Differential Output Pair	Differential output for 5 / 10 Gbps USB signals. Must be externally AC-coupled.
12	TX+		

NB7VPQ701M

DEVICE CONFIGURATION

Table 2. CONTROL PIN EFFECTS (Typical Values)

Pin	Description	Logic State	Equalization Gain		
EQ	Equalization Amount	Low	3 dB		
		Floating	6 dB		
		High	9 dB		
Pin	Description	Logic State	De-emphasis Ratio (Note 1)		
			OS = LOW	OS = Float	OS = High
DE	De-Emphasis Amount	Low	0 dB	-4 dB	-6 dB
		Floating	-3 dB	-5.5 dB	-7.5 dB
		High	-5.5 dB	-7 dB	-9 dB
Pin	Description	Logic State	Output Swing		
OS	Output Swing with DE Pin Low (0 dB)	Low	750 mV _{PP}		
		Floating	900 mV _{PP}		
		High	1000 mV _{PP}		

1. dB Decrease = $20 \log * (VTX-DE / VTX-DIFF-PP)$

Table 3. ATTRIBUTES

Parameter		
ESD Protection	Human Body Model Charged Device Model	> 4 kV > 1.5 kV
Moisture Sensitivity, Indefinite Time Out of Drypack (Note 2)		Level 1
Flammability Rating	Oxygen Index: 28 to 34	UL 94 V-O @ 0.125 in
Transistor Count		704
Meets or exceeds JEDEC Spec EIA/JESD78 IC Latchup Test		

2. For additional information, see Application Note AND8003/D.

Table 4. ABSOLUTE MAXIMUM RATINGS

Over operating free-air temperature range (unless otherwise noted)

Parameter	Description	Min	Max	Unit
Supply Voltage (Note 3)	V _{CC}	-0.3	2.5	V
Voltage range at any input or output terminal	Differential I/O	-0.5	1.89	V
	LVC MOS inputs	-0.3	V _{CC} + 0.3	V
Electrostatic discharge	Human body model (all pins) (Note 4)		±4	kV
	Charged device model (all pins) (Note 4)		±1.5	kV
Storage temperature, T _{SG}		-65	150	°C
Maximum junction temperature, T _J		-40	125	°C
Junction-to-ambient thermal resistance, θ _{JA}			138	°C/W

Stresses exceeding those listed in the Maximum Ratings table may damage the device. If any of these limits are exceeded, device functionality should not be assumed, damage may occur and reliability may be affected.

3. All voltage values are with respect to the GND terminals.

4. Tested in accordance with JEDEC Standard.

NB7VPQ701M

Table 5. RECOMMENDED OPERATING CONDITIONS

Over operating free-air temperature range (unless otherwise noted)

Parameter	Description	Min	Nom	Max	Unit
V _{CC}	Main power supply	1.71	1.8	1.89	V
T _A	Operating free-air temperature	-40		+85	°C
C _{AC}	AC coupling capacitor	75	100	200	nF

Functional operation above the stresses listed in the Recommended Operating Ranges is not implied. Extended exposure to stresses beyond the Recommended Operating Ranges limits may affect device reliability.

Table 6. POWER SUPPLY CHARACTERISTICS

Parameter		Test Conditions	Min	Typ (Note 5)	Max	Unit
I _{CC}	Active	Link in U0 with SS data transmission DE = low 0 dB, EQ = low 3 dB, OS = low		65		mA
	Idle State	Link has some activity, not in U0 DE = float -3 dB, EQ = float 6dB OS = low		49		mA
	U2/U3	Link in U2 or U3 power saving state DE = float -3 dB, EQ = float 6 dB, OS = low		4.5		mA
	No USB Connection	No connection state, termination disabled DE = float -3 dB, EQ = float 6 dB, OS = low		4.5		mA
	Deep Power-Saving State	Part disabled by EN pin EN = low		28		μA

5. TYP values use V_{CC} = 1.8 V, T_A = 25°C.

Table 7. LVCMOS CONTROL PIN CHARACTERISTICS

Parameter	Test Conditions	Min	Typ	Max	Unit
3-State LVCMOS Inputs (EQ, DE, OS) and 2-State LVCMOS Inputs (EN)					
V _{IH}	High-level input voltage	0.8 * V _{CC}			V
V _{IM}	Mid-level input voltage		V _{CC} / 2		V
V _{IL}	Low-level input voltage			0.2 * V _{CC}	V
V _F	Floating voltage	V _{IN} = High impedance	V _{CC} / 2		V
R _{PU}	Internal pull-up resistance		250		kΩ
R _{PD}	Internal pull-down resistance		250		kΩ
I _{IH}	High-level input current	V _{IN} = 1.89 V		20	μA
I _{IL}	Low-level input current	V _{IN} = GND, V _{CC} = 1.89 V	-20		μA

NB7VPQ701M

Table 8. RECEIVER AC/DC CHARACTERISTICS Over operating free-air temperature range (unless otherwise noted)

Parameter		Test Conditions	Min	Typ	Max	Unit
VRX-DIFF-pp	Input differential voltage swing	AC-coupled, peak-to-peak	250		1200	mV _{PP}
VRX-CM	Common-mode voltage bias in the receiver (DC)			V _{CC} -0.25		V
ZRX-DIFF	Differential input impedance (DC)	Present after an USB device is detected on TX+/TX-	80	100	120	Ω
ZRX-CM	Common-mode input impedance (DC)	Present after an USB device is detected on TX+/TX-	20	25	30	Ω
ZRX-HIGH-IMP	Common-mode input impedance with termination disabled (DC)	Present when no USB device is detected on TX+	25	35		kΩ
VTH-LFPS-pp	Low Frequency Periodic Signaling (LFPS) Detect Threshold	Output voltage is considered squelched below this threshold voltage.			300	mV _{PP}

Table 9. TRANSMITTER AC/DC CHARACTERISTICS Over operating free-air temperature range (unless otherwise noted)

Parameter		Test Conditions	Min	Typ	Max	Unit
VTX-DIFF-PP	Output differential voltage swing at 5 Gbps, 10 Gbps with DE low (0 dB)	OS = Low, 50 Ω to V _{CC}		750		mV _{PP}
		OS = Float, 50 Ω to V _{CC}		900		
		OS = High, 50 Ω to V _{CC}		1000		
CTX	TX input capacitance to GND	At 2.5 GHz		1.25		pF
ZTX-DIFF	Differential output impedance (DC)	Present after an USB device is detected on TX+/TX-	80	100	120	Ω
ZTX-CM	Common-mode output impedance (DC)	Present after an USB device is detected on TX+/TX-	20		30	Ω
ITX-SC	TX short circuit current	TX± shorted to GND		60		mA
VTX-CM	Common-mode voltage bias in the transmitter (DC)			V _{CC} -0.5	V _{CC}	V
VTX-CM-ACpp	AC common-mode peak-to-peak voltage swing in active mode	Within U0 and within LFPS			100	mV _{PP}
VTX-IDLE-DIFF-ACpp	Differential voltage swing during electrical idle	Tested with a high-pass filter	0		10	mV _{PP}
VTX-RXDET	Voltage change to allow receiver detect	Positive voltage to sense receiver termination			600	mV
t _R , t _F	Output rise, fall time	20% – 80% of differential voltage measured 1 inch from the output pin		45		ps
t _{RF-MM}	Output rise, Fall time mismatch	20% – 80% of differential voltage measured 1 inch from the output pin			5	ps
t _{diff-LH} , t _{diff-HL}	Differential propagation delay	De-emphasis = -3 dB, OS = Low propagation delay between 50% level at input and output		150		ps
t _{idleEntry} , t _{idleExit}	Idle entry and exit times			30		ns

NB7VPQ701M

Table 10. TIMING AND JITTER CHARACTERISTICS

Parameter	Test Conditions	Min	Typ	Max	Unit	
TIMING						
tREADY	Time from power applied until RX termination is enabled	Apply 0 V to V _{CC} , connect USB termination to TX±, apply 1.8 V to V _{CC} , and measure when ZRX-DIFF is enabled		10		ms

JITTER FOR 5 Gbps

TJTX-EYE	Total jitter (Notes 6, 7)	EQ = Float 6 dB, DE = High -5.5 dB, OS = Low		0.087		UI (Note 8)
DJTX	Deterministic jitter (Note 7)			0.023		UI (Note 8)
RJTX	Random jitter (Note 7)			0.006		UI (Note 8)

JITTER FOR 10 Gbps

TJTX-EYE	Total jitter (Notes 6, 7)	EQ = Float 6dB, DE = High -5.5 dB, OS = Low		0.207		UI (Note 8)
DJTX	Deterministic jitter (Note 7)			0.082		UI (Note 8)
RJTX	Random jitter (Note 7)			0.013		UI (Note 8)

6. Includes RJ at 10⁻¹².

7. Measured at the ends of reference channel with a K28.5 pattern, VID = 1000 mVpp, -3.5 dB de-emphasis from source.

8. 5 Gbps, UI = 200 ps for 10 Gbps, UI = 100 ps

NB7VPQ701M

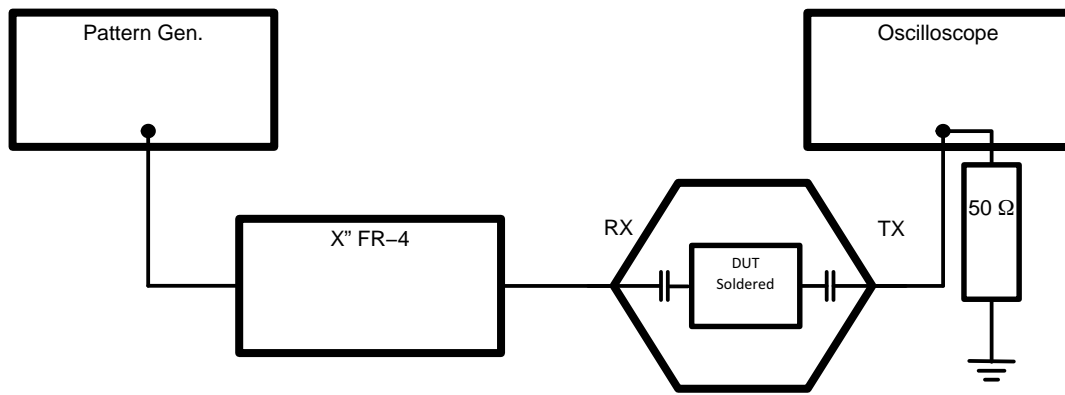

Figure 3. Equalization Measurement Setup

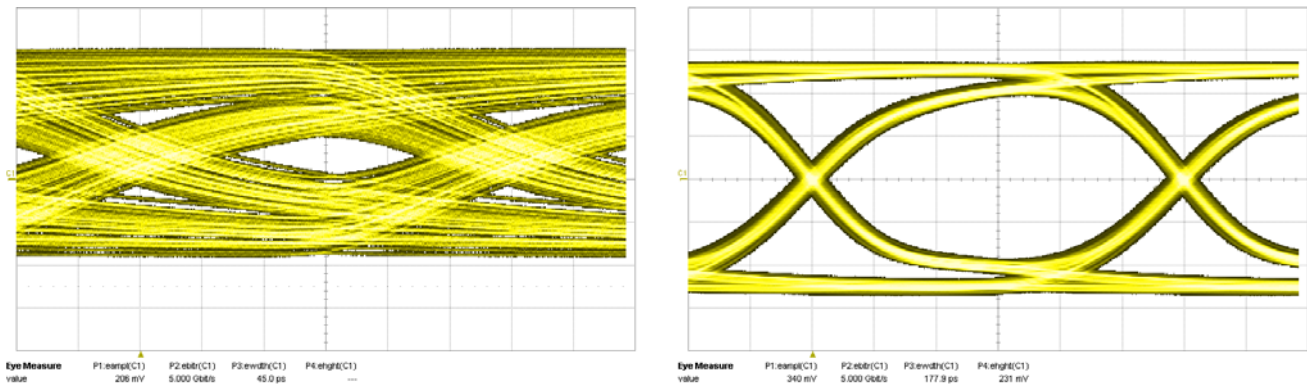

Figure 4. 5 Gbps Signal with 24 inches of FR4 Before Input to NB7VPQ701M and After Using High EQ Setting

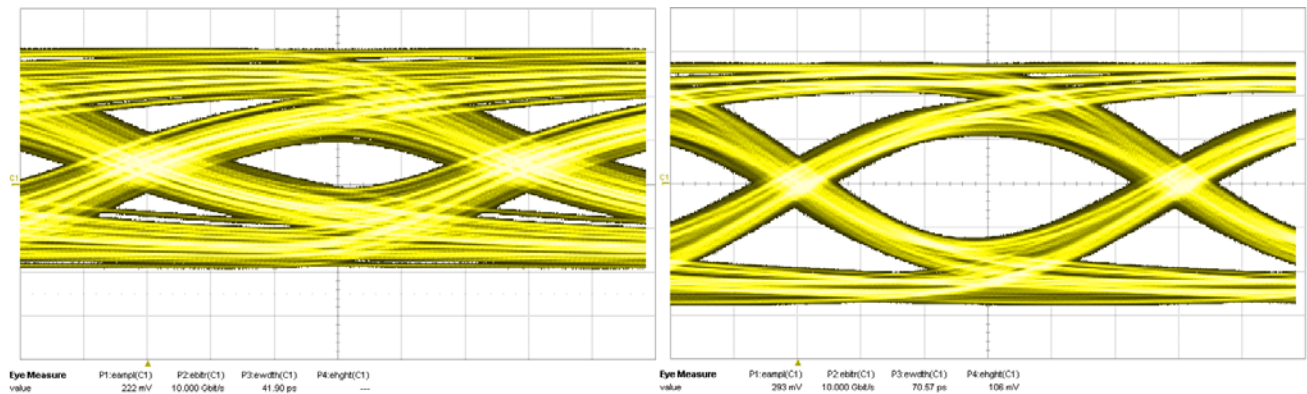

Figure 5. 10 Gbps Signal with 12 inches of FR4 Before Input to NB7VPQ701M and After with EQ Floating (Mid)

NB7VPQ701M

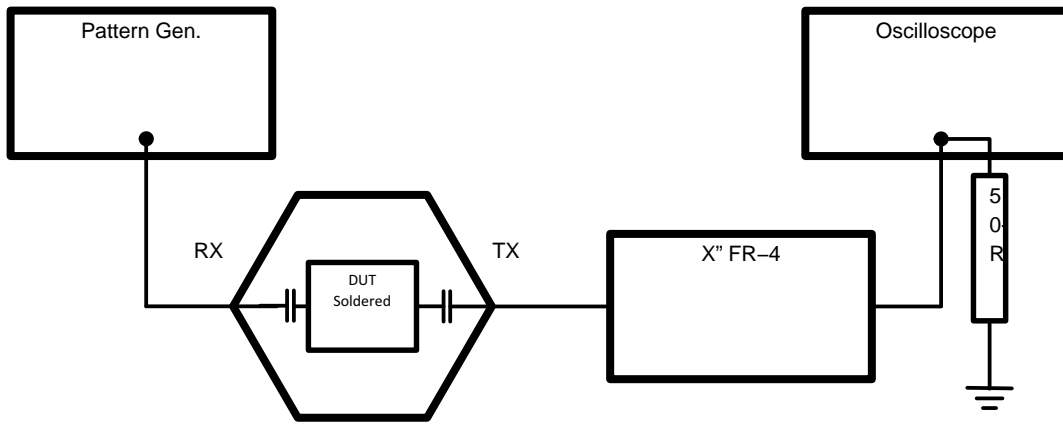

Figure 6. De-Emphasis Measurement Setup

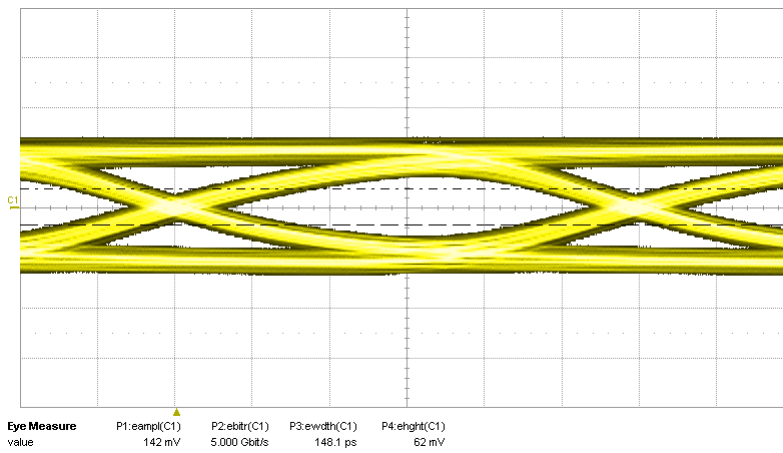

Figure 7. 5 Gbps Signal After 24 inches of FR4 at Output with High DE Setting to NB7VPQ701M

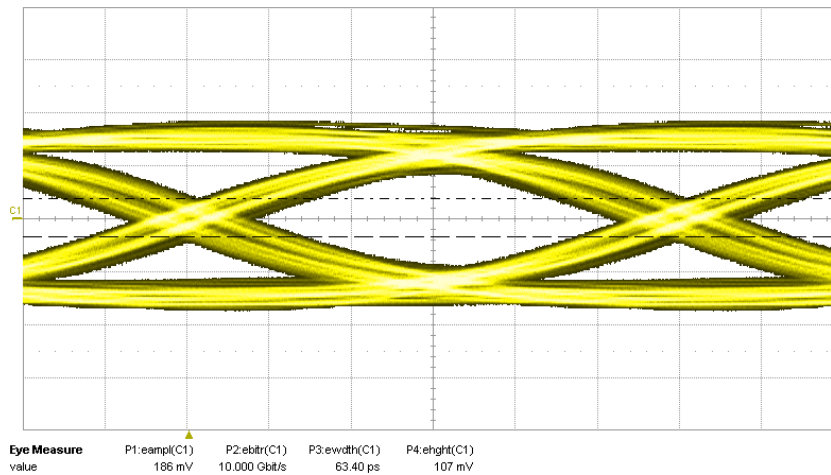

Figure 8. 10 Gbps Signal After 9 inches of FR4 at Output with High DE Setting to NB7VPQ701M

NB7VPQ701M

PARAMETER MEASUREMENT DIAGRAMS

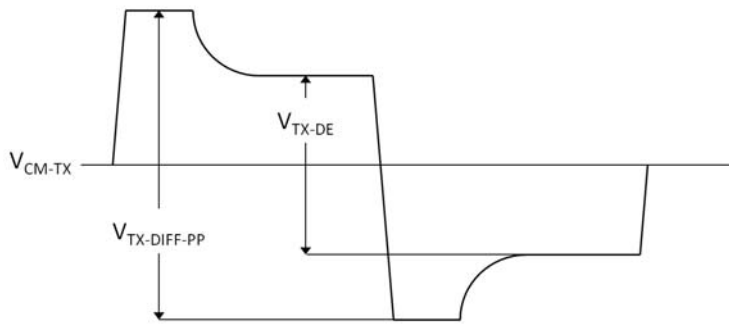

Figure 9. Transmitter Differential Voltage
 $\text{dB Decrease} = 20 \log * (V_{\text{TX-DE}} / V_{\text{TX-DIFF-PP}})$

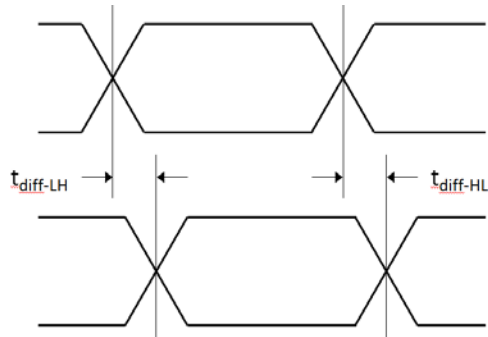

Figure 10. Propagation Delay

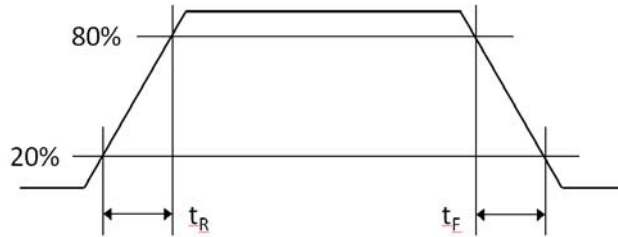

Figure 11. Output Rise and Fall Times

APPLICATION GUIDELINES

LFPS Compliance Testing

As part of USB 3.1 compliance test, the host or peripheral must transmit a LFPS signal that adheres to the spec parameters. When using a real-time oscilloscope to capture this data, *the scope's trigger must be below 0 V when making single-ended measurements*. Although the differential signal is identical to that which is expected by the USB 3.1 system, the AC common mode voltage for LFPS may fall below 0 V during short bursts of switching signal, which is still within the spec's limit.

Ping.LFPS for TX Compliance

During the transmitter compliance, the system under test must transmit certain compliance patterns as defined by the USB-IF. In order to toggle through these patterns for various tests, the receiver must receive a ping. LFPS signal from either the test suite or a separate pattern generator. The standard signal comprises of a single burst period of 100ns at 20 MHz. In order to pass this signal through NB7VPQ701M, *the duration of the burst must be extended to at least 200 ns*.

NB7VPQ701M

PACKAGE DIMENSIONS

UQFN12, 1.6x1.6, 0.4P CASE 523AV ISSUE A

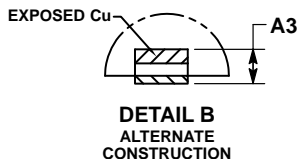
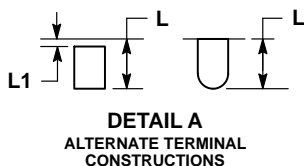
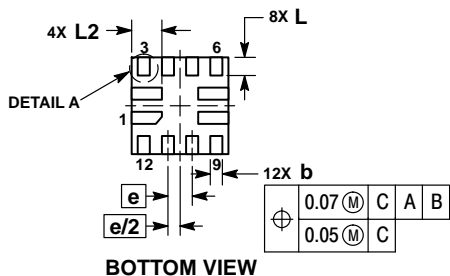
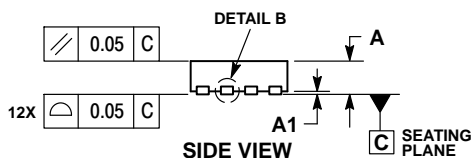
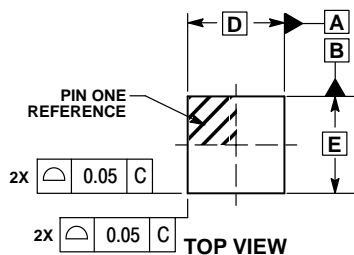

NOTES:

1. DIMENSIONING AND TOLERANCING PER ASME Y14.5M, 1994.
2. CONTROLLING DIMENSION: MILLIMETERS.
3. DIMENSION b APPLIES TO PLATED TERMINAL AND IS MEASURED BETWEEN 0.15 AND 0.25 mm FROM THE TERMINAL TIP.

MILLIMETERS		
DIM	MIN	MAX
A	0.45	0.55
A1	0.00	0.05
A3	0.152	REF
b	0.15	0.25
D	1.60	BSC
E	1.60	BSC
e	0.40	BSC
L	0.20	0.40
L2	0.40	0.60

SOLDERING FOOTPRINT*

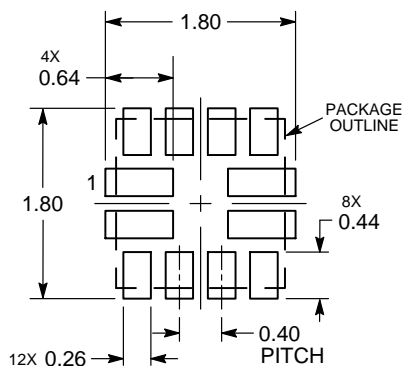

DIMENSIONS: MILLIMETERS

*For additional information on our Pb-Free strategy and soldering details, please download the ON Semiconductor Soldering and Mounting Techniques Reference Manual, SOLDERRM/D.

ON Semiconductor and are trademarks of Semiconductor Components Industries, LLC dba ON Semiconductor or its subsidiaries in the United States and/or other countries. ON Semiconductor owns the rights to a number of patents, trademarks, copyrights, trade secrets, and other intellectual property. A listing of ON Semiconductor's product/patent coverage may be accessed at www.onsemi.com/site/pdf/Patent-Marketing.pdf. ON Semiconductor reserves the right to make changes without further notice to any products herein. ON Semiconductor makes no warranty, representation or guarantee regarding the suitability of its products for any particular purpose, nor does ON Semiconductor assume any liability arising out of the application or use of any product or circuit, and specifically disclaims any and all liability, including without limitation special, consequential or incidental damages. Buyer is responsible for its products and applications using ON Semiconductor products, including compliance with all laws, regulations and safety requirements or standards, regardless of any support or applications information provided by ON Semiconductor. "Typical" parameters which may be provided in ON Semiconductor data sheets and/or specifications can and do vary in different applications and actual performance may vary over time. All operating parameters, including "Typicals" must be validated for each customer application by customer's technical experts. ON Semiconductor does not convey any license under its patent rights nor the rights of others. ON Semiconductor products are not designed, intended, or authorized for use as a critical component in life support systems or any FDA Class 3 medical devices or medical devices with a same or similar classification in a foreign jurisdiction or any devices intended for implantation in the human body. Should Buyer purchase or use ON Semiconductor products for any such unintended or unauthorized application, Buyer shall indemnify and hold ON Semiconductor and its officers, employees, subsidiaries, affiliates, and distributors harmless against all claims, costs, damages, and expenses, and reasonable attorney fees arising out of, directly or indirectly, any claim of personal injury or death associated with such unintended or unauthorized use, even if such claim alleges that ON Semiconductor was negligent regarding the design or manufacture of the part. ON Semiconductor is an Equal Opportunity/Affirmative Action Employer. This literature is subject to all applicable copyright laws and is not for resale in any manner.

PUBLICATION ORDERING INFORMATION

LITERATURE FULFILLMENT:

Literature Distribution Center for ON Semiconductor
19521 E. 32nd Pkwy, Aurora, Colorado 80011 USA
Phone: 303-675-2175 or 800-344-3860 Toll Free USA/Canada
Fax: 303-675-2176 or 800-344-3867 Toll Free USA/Canada
Email: orderlit@onsemi.com

N. American Technical Support: 800-282-9855 Toll Free
USA/Canada
Europe, Middle East and Africa Technical Support:
Phone: 421 33 790 2910
Japan Customer Focus Center
Phone: 81-3-5817-1050

ON Semiconductor Website: www.onsemi.com
Order Literature: <http://www.onsemi.com/orderlit>

For additional information, please contact your local Sales Representative